



Telescoping Crawler Crane

CC985S-2

EU Stage V Compliant Engine **NEW**

- Optional Fly Jib (430kg)
- Optional Searcher Hook (2.0t)
+ Single Fall Hook (1.5t)



- Optional Blade

Crane Capacity Max. Lifting Height Pick & Carry Duty
4.9t × 2.1m 16.5m 2,000kg
 Max. Lifting Height with Optional Fly Jib : **20.2m**

STAGE V

Minimal Tail Swing



Wide View Roof Window



Programmable Moment Limiter



7 inch Multi Monitor

4 Fall / 2 Fall Hook Block



EU Stage V Compliant Engine



Rear View Camera & Monitor



Specifications

Model		CC985S-2	
Crane capacity	4.9t x 2.1m		
Max. working radius	14.67m x 0.20t		
Max. lifting height	16.5m (20.2m with fly jib)		
Max. reach below ground	-25.0m (4 falls) / -50.0m (2 falls) / -100.0m (1 fall)		
Pick & Carry capacity	2.0t		
Machine Weight	9,510kg (9,910kg w/blade, 9,690kg w/fly jib, 10,090kg w/blade & fly jib)		
Machine Weight with rubber pads	9,790kg (10,190kg w/blade, 9,970kg w/fly jib, 10,370kg w/blade & fly jib)		
Overall length x width x height	5,190mm x 2,320mm x 2,730mm		
Overall length x width x height (with rubber pads)	5,220mm x 2,320mm x 2,760mm		
Crawler width	450mm		
Tail swing	1,390mm		
Winch system	Number of wire falls for Hook		4 falls / 2 falls
	Hook speed	Low	29.0m/min (4 layers, 4 falls)
		High	38.0m/min (4 layers, 4 falls)
	Hoist wire rope		IWRC 6 x Fi(29) φ10mm x 115m
Telescopic system	Boom type Fully automatic 5-section pentagonal telescopic boom		
	Boom length		4.78m - 7.53m - 10.28m - 13.03m - 15.78m
	Boom telescoping stroke / time		11.0m / 24sec
Boom hoist system	Hoist angle / time		-2 ~ 80degree / 13sec
Slew system	Slew angle / time 360deg / 2.1rpm		
	Travel speed	Low	Forward & backward 0~2.1km/h
High		Forward & backward 0~3.4km/h	
Drive system	Gradability 20deg		
	Ground pressure with rubber pads 47.8kPa (0.49kgf/cm ²) [50.6kPa (0.52kgf/cm ²) w/blade & fly jib]		
	Model ISUZU 4LE2XBJB		
Engine	Emission level EU Stage V		
	Displacement 2.179L (2,179cc)		
	Rated output 44.6kW / 2,000min ⁻¹ (60.6PS / 2,000rpm)		
	Fuel / Fuel tank capacity Diesel / 140.0L		
Safety device	Hydraulic safety valve, Overwind protection, Level, Safety lock lever, Tilt alarm, EMO switch, Moment limiter, LED working status lamp, Rear view camera, Data logger		
Optional equipment	Rubber pads (weight 280kg), Single fall hook, Blade, Fly jib (430kg capacity), Searcher hook (2,000kg capacity)		

Telescoping Crawler Crane

NEW

CC985S-2 EU Stage V Compliant Engine

Dimensions

(mm)

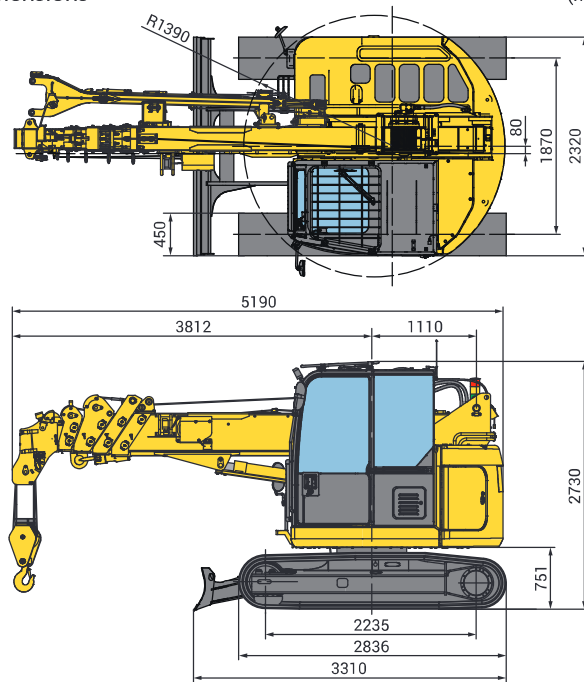

Working Range Chart (4 falls)

(kg)

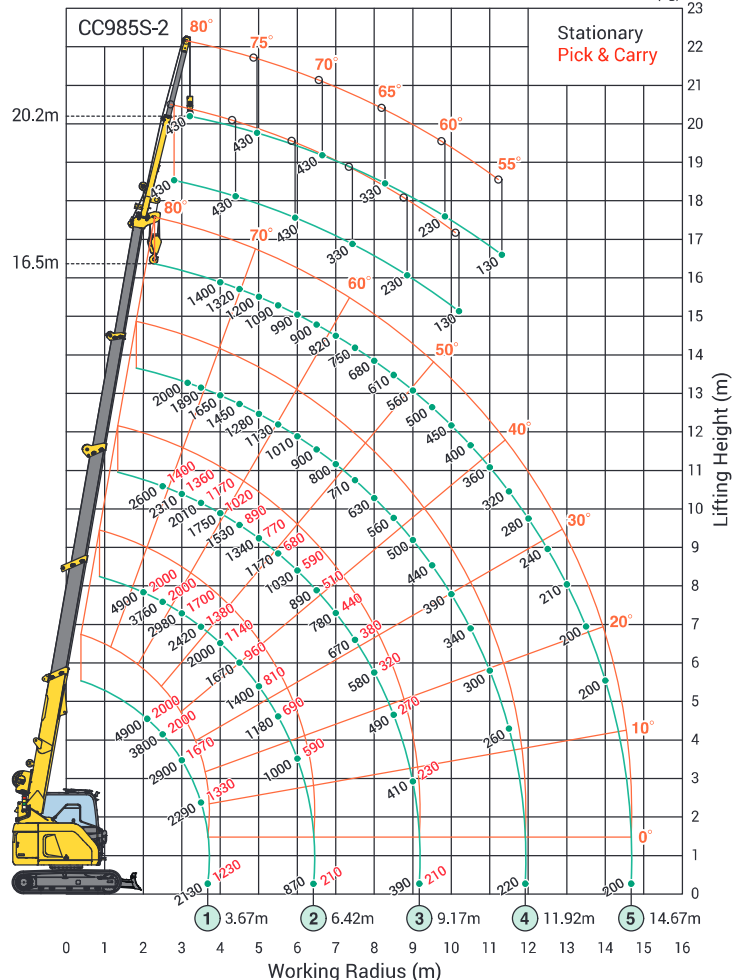

Rated Total Load Chart (4 falls)

unit: kg

Working radius (m)	4.78m Boom		7.53m Boom		10.28m Boom		13.03m Boom		15.78m Boom	
	Stationary	Pick & Carry	Stationary	Pick & Carry	Stationary	Pick & Carry	Stationary	Pick & Carry	Stationary	Pick & Carry
2.00	4900	2000	4900	2000	2600	1400	2000			
2.10	4900	2000	4630	2000	2600	1400	2000			
2.50	3800	2000	3760	2000	2600	1400	2000		1400	
2.70	3310	1950	3410	1940	2520	1400	2000		1400	
3.00	2900	1670	2980	1700	2310	1360	2000		1400	
3.15	2640	1550	2800	1590	2220	1300	2000		1400	
3.50	2290	1330	2420	1380	2010	1170	1890		1400	
3.67	2130	1230	2270	1290	1920	1120	1800		1400	
4.00			2000	1140	1750	1020	1650		1400	
4.50			1670	960	1530	890	1450		1320	
5.00			1400	810	1340	770	1280		1200	
5.50			1180	690	1170	680	1130		1090	
6.00			1000	590	1030	590	1010		990	
6.42			870	510	910	520	910		920	
6.50					890	510	900		900	
7.00					780	440	800		820	
7.50					670	380	710		750	
8.00					580	320	630		680	
8.50					490	270	560		610	
9.00					410	230	500		560	
9.17					390	210	480		540	
9.50							440		500	
10.00							390		450	
10.50							340		400	
11.00							300		360	
11.50							260		320	
11.92							220		280	
12.00									280	
12.50									240	
13.00									210	
13.50									200	
14.00									200	
14.67									200	

*The Rated Total Load Chart is based on the actual working radius including boom deflection.
 *The weight of hook block (standard 4 fall/2fall-90kg) must be included as part of the load shown in the Rated Total Load Chart.
 **When using two fall or single fall hooks, use the appropriate four fall Rated Total Load Chart above but with a maximum load of: Two fall-2450kg, Single fall-1220kg.

Due to improvements, the specifications are subject to change without notice.

Before use, please read the Operation Manual



MAEDA SEISAKUSHO CO.,LTD.

No.1095, Onbegawa, Shinonoi, Nagano-City, Nagano-Pref. 388-8522 Japan
 Head office TEL:+81(0)26 292 2228 FAX:+81(0)26 293 5590
 URL : www.maedaminicranes.com E-mail : contact@maeda-minicranes.com